

HONDA CRV 2004/05

MISUTONIDA
 italian style accessories **4x4**

MISUTONIDA s.r.l. - 12062 CHERASCO (CN) - Via Fondovalle n° 3
 Tel. 0172-489283 - Fax 0172-488381

Web Site: <http://www.misutonida.com> - E-mail: misutonida@misutonida.com

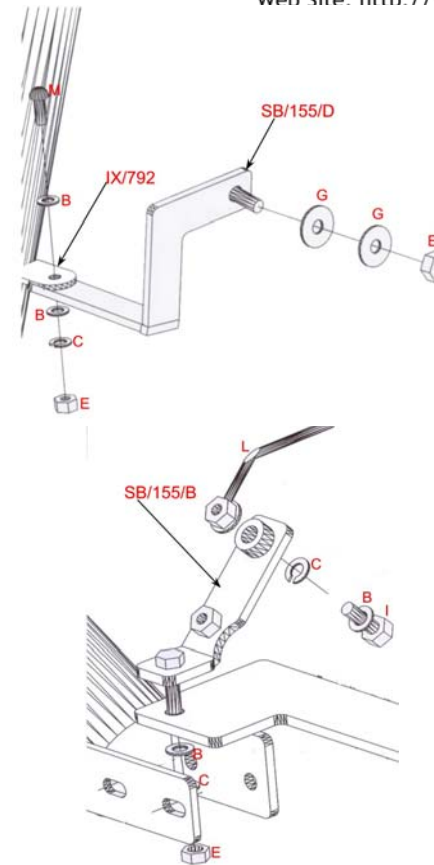
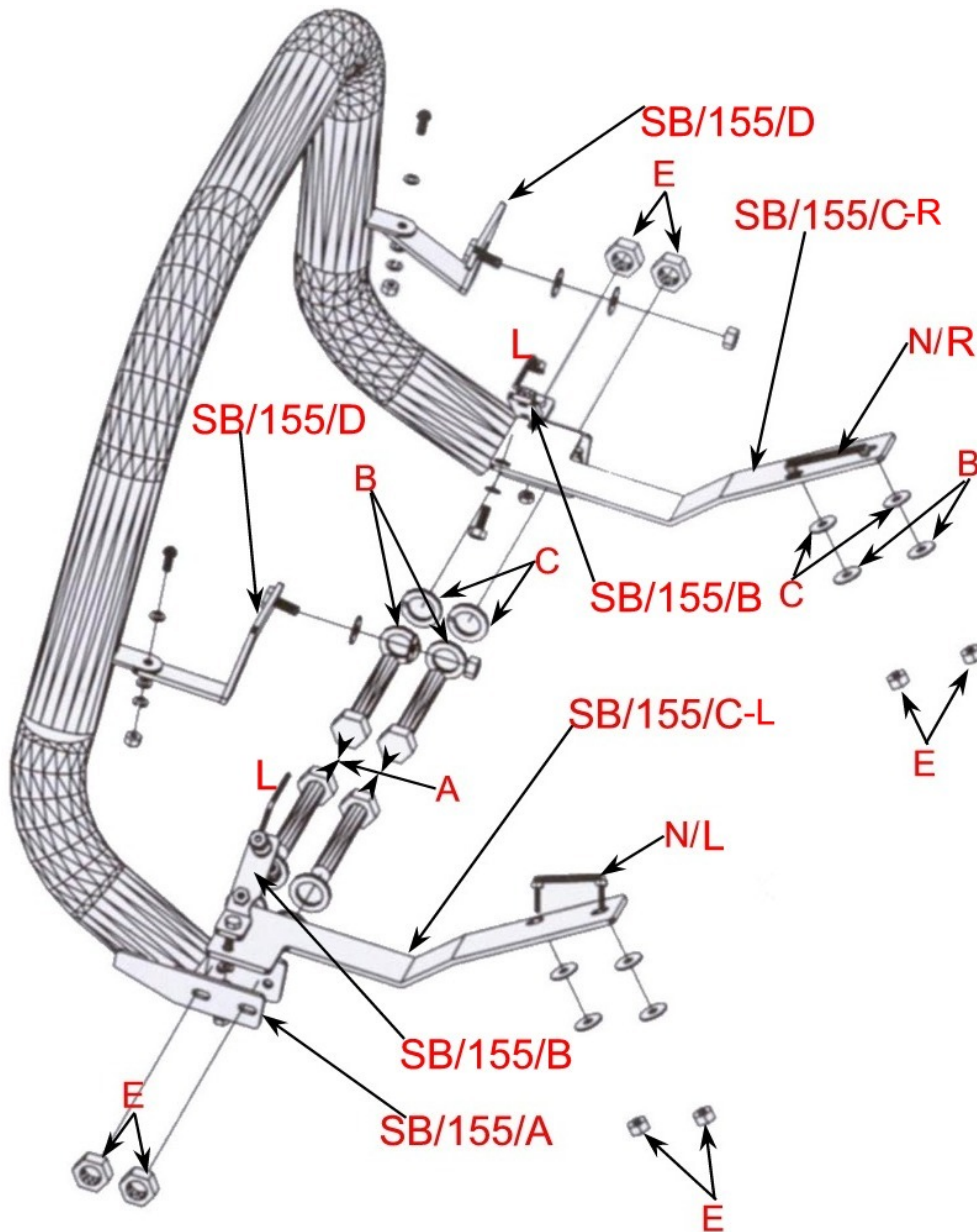

BULLONERIA ED ACCESSORI BOLT AND ACCESSORY SET OF BOLTS AND ACCESSORIES

4	TE 8x25 BOLT	A
12	ROND. Ø8 WASHER	B
16	GROWER Ø8	C
12	M8 NUT	E
4	ROND Ø10 WASHER	G
2	DADI M10 NUT	H
2	TE 8x30 BOLT	I
2	DADI M 8 CON ROND. E TONDINO SALDATO M8 NUTS WITH WASHER AND ROD WELDED	L
2	TBCEI 8 X 20 BOLT	M
2	TONDINI CON BULLONI TE8X20 SALDATI RONDS WITH TE 8X20 L&R BOLTS WELDED	N

R	DESTRA	RIGHT
L	SINISTRA	LEFT

	DATA	REALIZZATO DA:
	7/04/05	MANDALITI A.
	CONTROLLATO E APPROVATO DA	
	GALLO CLAUDIO	
OGGETTO: OBJECT:	SUPER BAR - SUPER BAR	
ARTICOLO: ITEM:	HONDA CRV 2004/05	
	SB/155/IX	Versione acciaio INOX AISI 304 Stainless Steel AISI 304 version

HONDA CRV 04/05



MISUTONIDA s.r.l. - 12062 CHERASCO (CN) - Via Fondovalle n° 3
Tel. 0172-489283 - Fax 0172-488381

Web Site: <http://www.misutonida.com> - E-mail: misutonida@misutonida.com

ISTRUZIONI DI MONTAGGIO



1. Smontare la maschera anteriore togliendo prima la protezione in plastica posta sopra la maschera anteriore (foto 1&2)
2. Allentare la protezione in plastica posta nella parte inferiore (foto 3)
3. montare staffe libere SB155D facendole passare nelle fessure della presa d'aria posta sotto il portatarga (foto 4)
4. inserire le staffe nel paraurti (foto 5) e serrare i bulloni M10 (foto 6)
5. Inserire i dadi M8 con rondella e tondino saldato nell'asola del paraurti (foto 7) e fissare le staffe SB155B ai dadi stessi (foto8)
6. inserire i tondini con bulloni M8 nei fori inferiori del telaio (foto 9) e fissare sugli stessi le staffe SB155C-R&L serrandole anche alle staffe SB155B.(foto 10) & (foto 11)
7. Rimontare la maschera, la protezione superiore e la protezione posta nella parte inferiore.
8. Montare SB fissando nella parte inferiore delle staffe SB 155 C-R&L nella parte inferiore e SB155D nella parte superiore.(foto 12)



FITTING INSTRUCTIONS

1. Disassemble the front grill by firstly removing the plastic protection placed over the front grill (picture 1 and 2)
2. Loosen the plastic protection placed in the lower part (picture 3)
3. assemble the free brackets SB 155D by making them pass through the hole in the air intake placed under the numberplate holder (picture 4)
4. Insert the brackets in the pre-existing holes in the bumper (picture 5) and tighten the M10 bolts (picture 6)
5. Insert the M8 nuts with washer and welded rod in the bumper's hole (picture 7) and fix the SB/155B brackets to the nuts (picture 7)
6. Insert the rods with M8 bolts in the lower holes on the chassis (picture 9) and fix the SB155C-DX and SX on them by tightening them also to the SB 155B brackets (picture 10 and 11)
7. Re-assemble the grill the upper protection and the protection placed in the lower part
8. Assemble the SB by fixing it in the lower part to the SB 155C DX and SX brackets and to the SB155D brackets the upper part (picture 12)



	DATA	REALIZZATO DA:
	22/12/04	MANDALITI A.
	CONTROLLATO E APPROVATO DA	
	GALLO CLAUDIO	
OGGETTO: OBJECT:	SUPER BAR - SUPER BAR	
	HONDA CRV 2004/05	
ARTICOLO: ITEM:	SB/155/IX	Versione acciaio INOX AISI 304 Stainless Steel AISI 304 version



HONDA CRV 04/5

MISUTONIDA
italian style accessories **4x4**

MISUTONIDA s.r.l. - 12062 CHERASCO (CN) - Via Fondovalle n° 3
Tel. 0172-489283 - Fax 0172-488381
Web Site: <http://www.misutonida.com> - E-mail: misutonida@misutonida.com



HONDA CRV 04/05

MISUTONIDA
italian style
accessories **4x4**

MISUTONIDA s.r.l. - 12062 CHERASCO (CN) - Via Fondovalle n° 3

Tel. 0172-489283 - Fax 0172-488381

Web Site: <http://www.misutonida.com> - E-mail: misutonida@misutonida.com



ARTICOLO: **SB/155/IX**
ITEM:

Versione acciaio INOX AISI 304
Stainless Steel AISI 304 version