

 **MISUTONIDA**
  *italian style* **4x4**
accessories

OPEL ANTARA



Item Code

Codice Articolo

Référence Article

: **GP/202/IX**
GPO/202/IX
DSP/202/IX

GB

STAINLESS STEEL GRAND PEDANA/OVAL GRAND
PEDANA/DESIGN SIDE PROTECTION







ITA

GRAND PEDANA/ GRAND PEDANA OVALE/
PROTEZIONE LATERALE DESIGN IN ACCIAIO
INOX

FR

GRAND PEDANA/ GRAND PEDANA OVALE/
PROTECTION LATERALE DESIGN EN ACCIER
INOX

OPEL ANTARA

Part List Lista della bulloneria Liste des pièces	
A	TE 10X50  x 4
B	M10 Autoblocking Autobloccante Autobloquant x 4
C	TE 8X25  x 10
D	Ø 8  x 12
E	Ø 8  x 12
F	M8  x 2
G	S/190/A  x 2
H	S/190/P  x 2

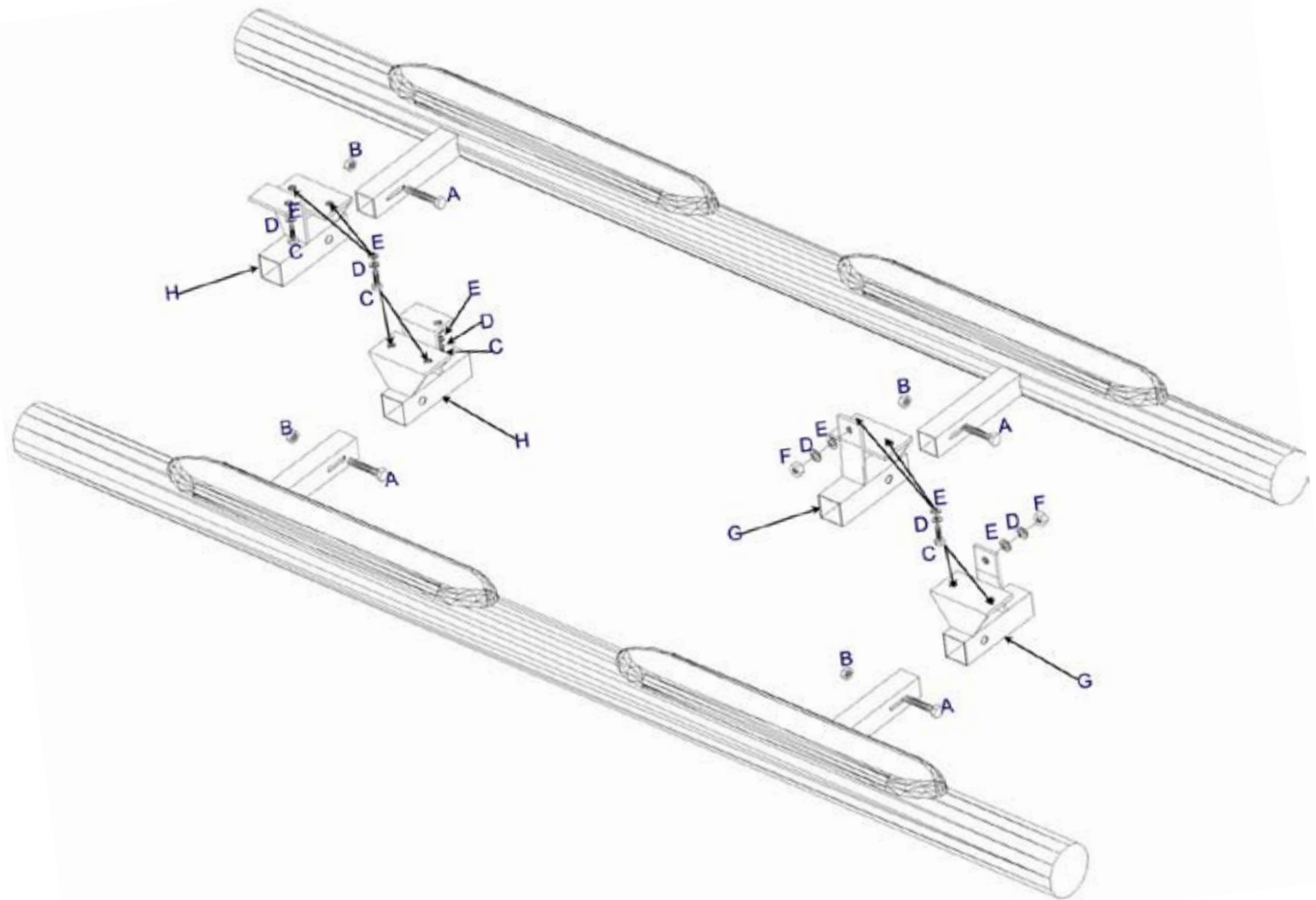

MISUTONIDA
italian style accessories **4x4**

GB**FITTING
INSTRUCTIONS**

1. Remove the n.8 plastic caps located in the threaded holes indicated pictures 1 and 2.
2. Fit G and H brackets as shown in pictures 3 and 4 using C,D,E, and F.
3. Assemble the grand pedana by positioning the brackets at the desired distance and tighten all the bolts.

**ITA****ISTRUZIONI DI
MONTAGGIO**

1. Rimuovere i n.8 tappi in plastica posti nei fori filettati indicati nelle foto 1 e 2.
2. Montare le staffe G ed H come indicato nelle foto 3 e 4 utilizzando C,D,E e F.
3. Montare la grand pedana posizionando le staffe alla distanza desiderata e serrare tutta la bulloneria.

**FR****INSTRUCTIONS DE
MONTAGE**

1. Enlever les n.8 bouchons en plastique positionnés dans les trous filetés indiqués dans les photos 1 et 2.
2. Monter les étriers G et H comme indiqué dans les photos 3 et 4 en utilisant C,D,E e F.
3. Monter la grand pedana en positionnant les étriers à la distance désirée et serrer toute la boulonnerie.



Date Data Date	Item Code Cod.Articolo Réf. Article	Vehicle model Modello Veicolo Modèle de Voiture
07/05/07	GP/202/IX GPO/202/IX DSP/202/IX	OPEL ANTARA

Checked and approved by
Controllato ed approvato da
 Controlé et approuvé par

**Botta
Pietro**